

# 11. Schematic Diagrams

## 11-1 MAIN (Power 21")

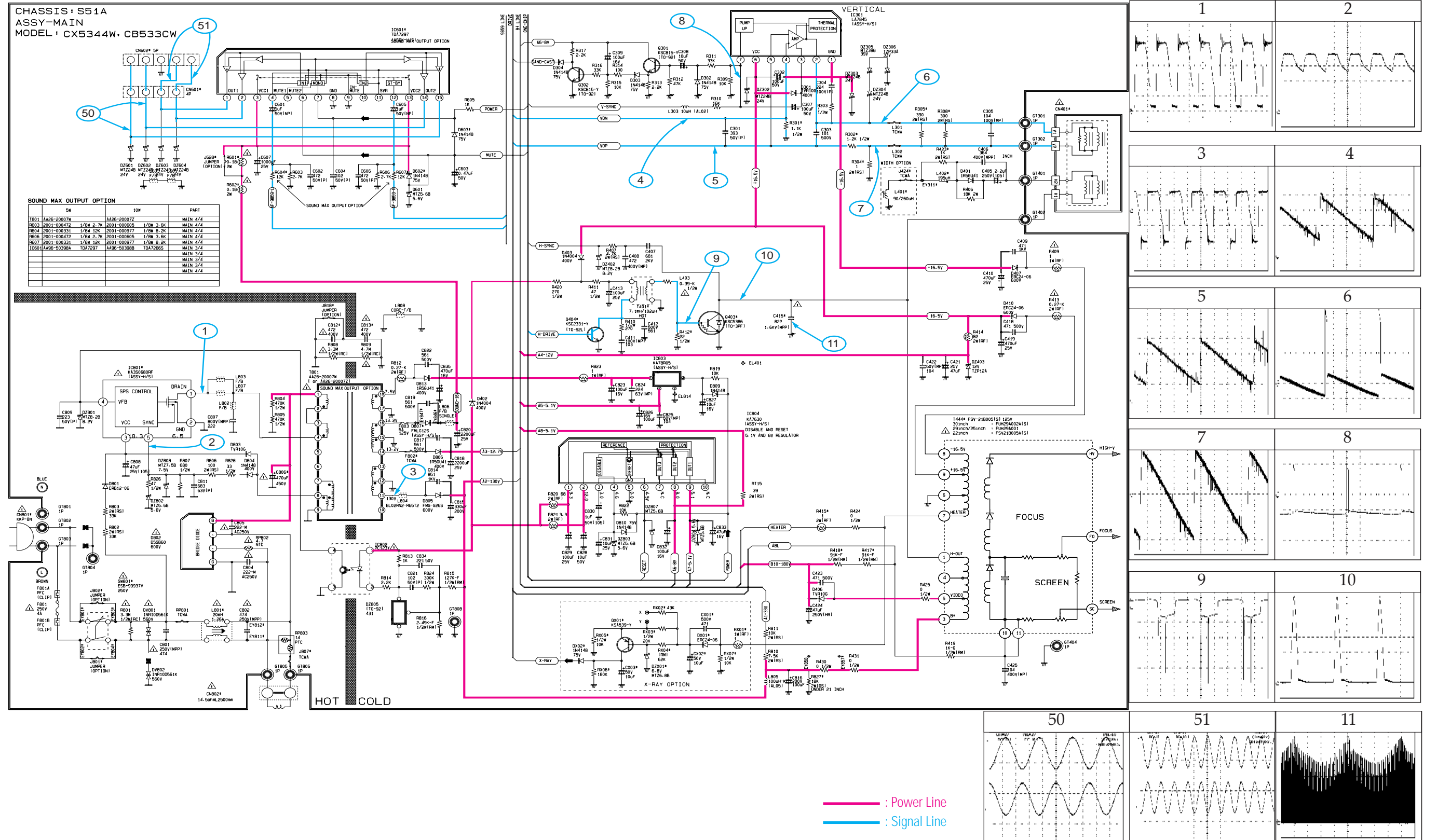

# 11-2 MAIN (Power 25" - 30")

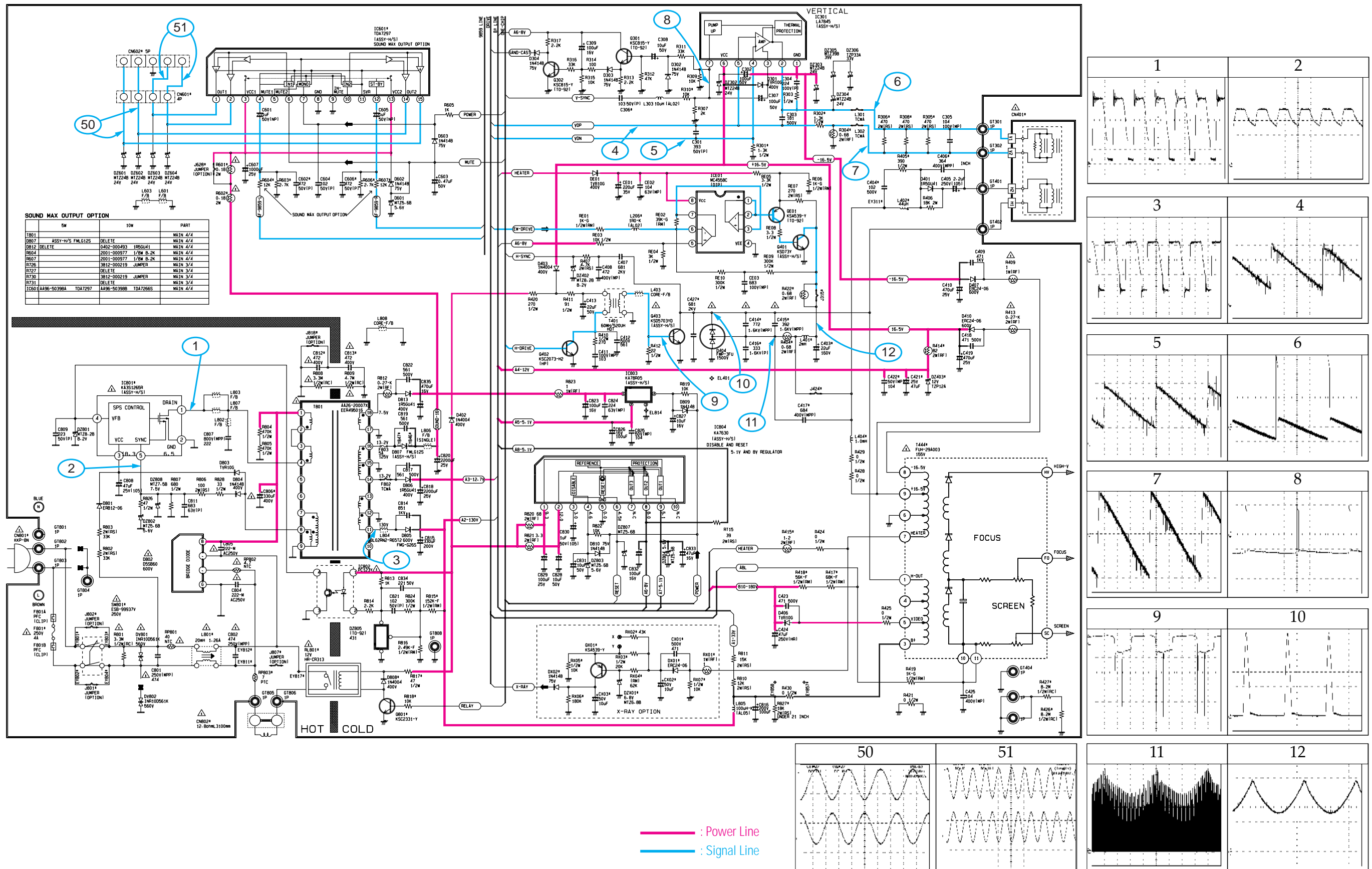

### 11-3 PWB MAIN (One-Chip)

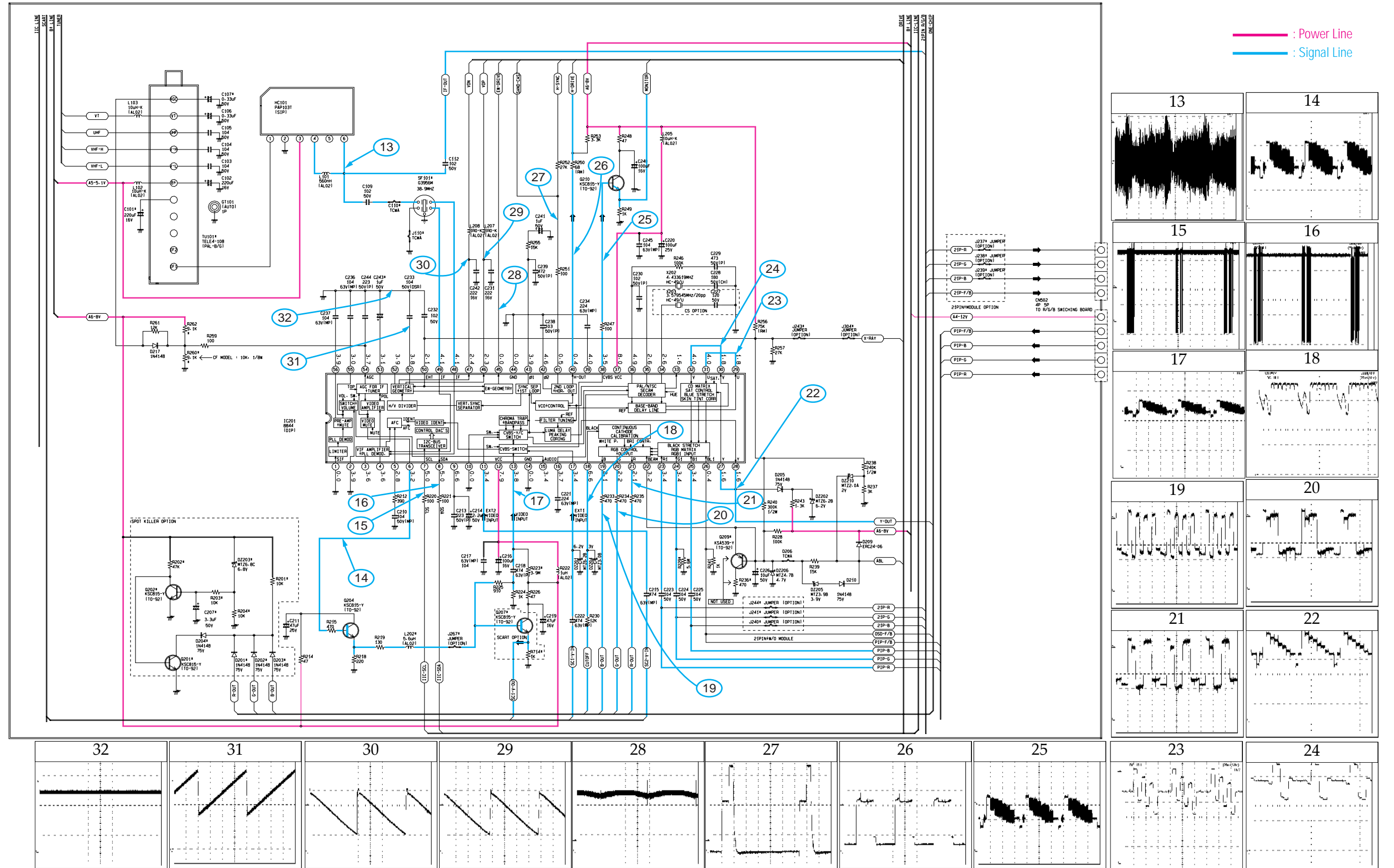

### 11-4 PWB MAIN (u-COM)

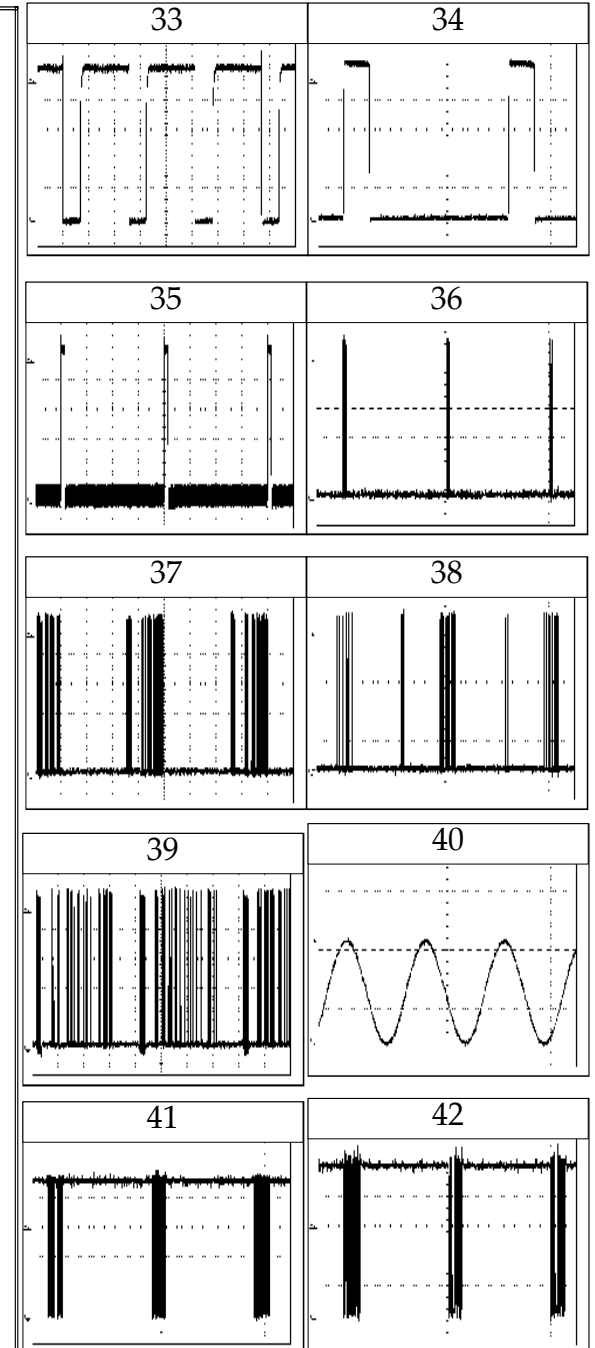
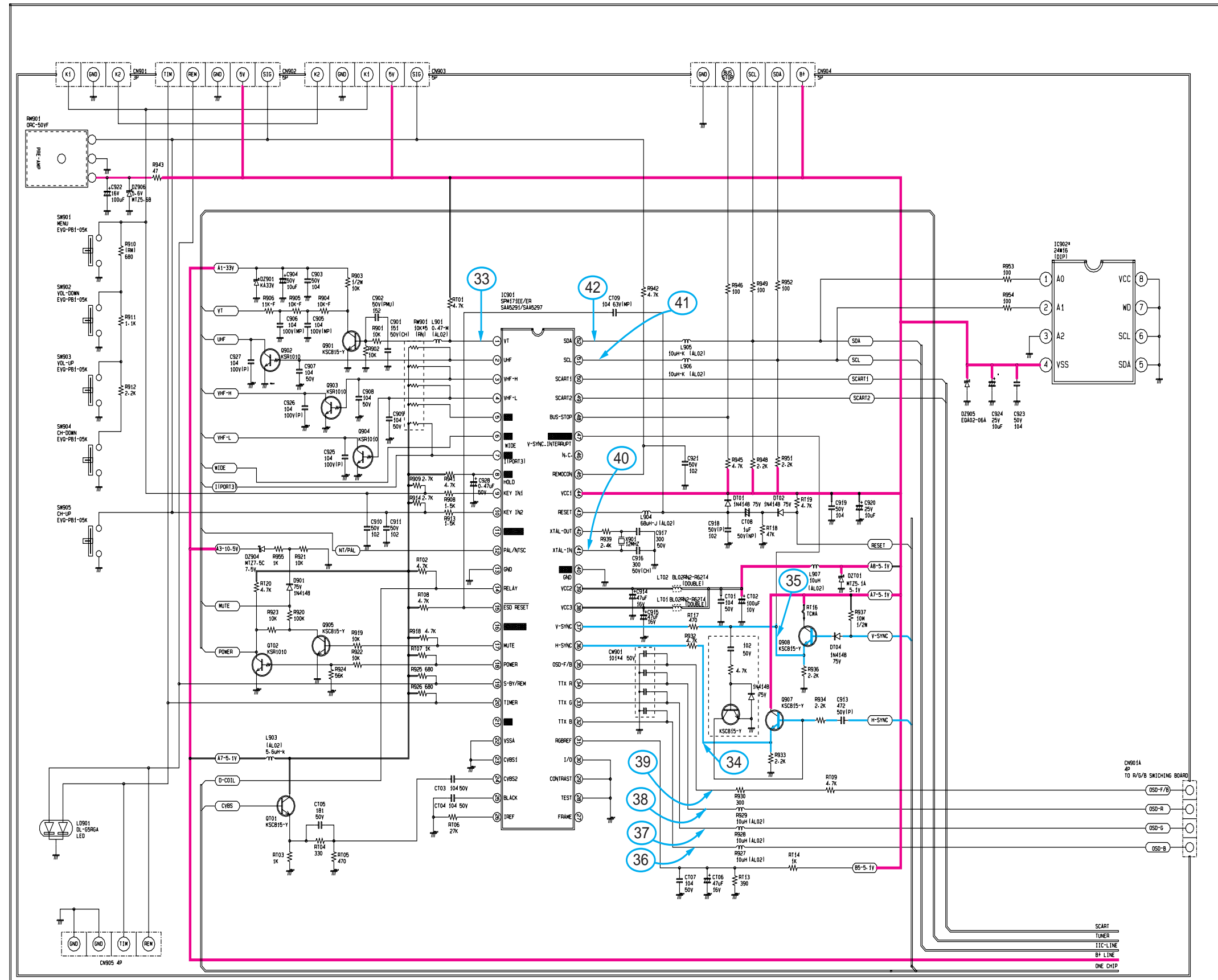

— : Power Line  
— : Signal Line



11-5 PWB-MAIN (u-COM)

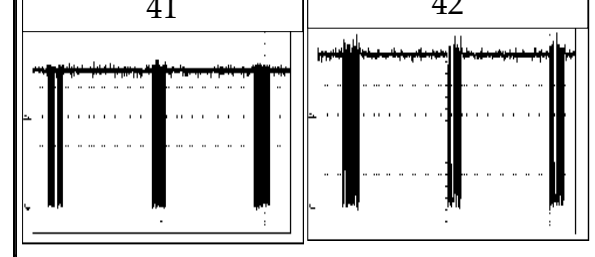
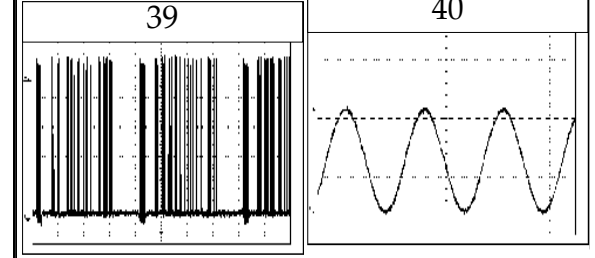
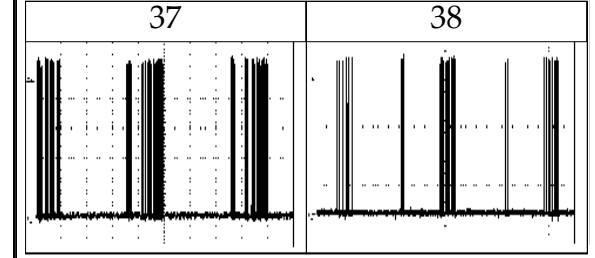
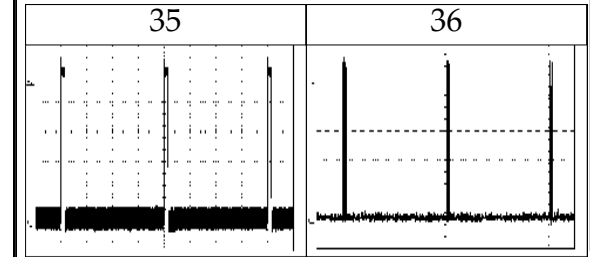
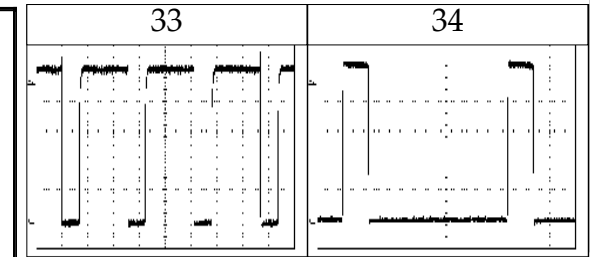
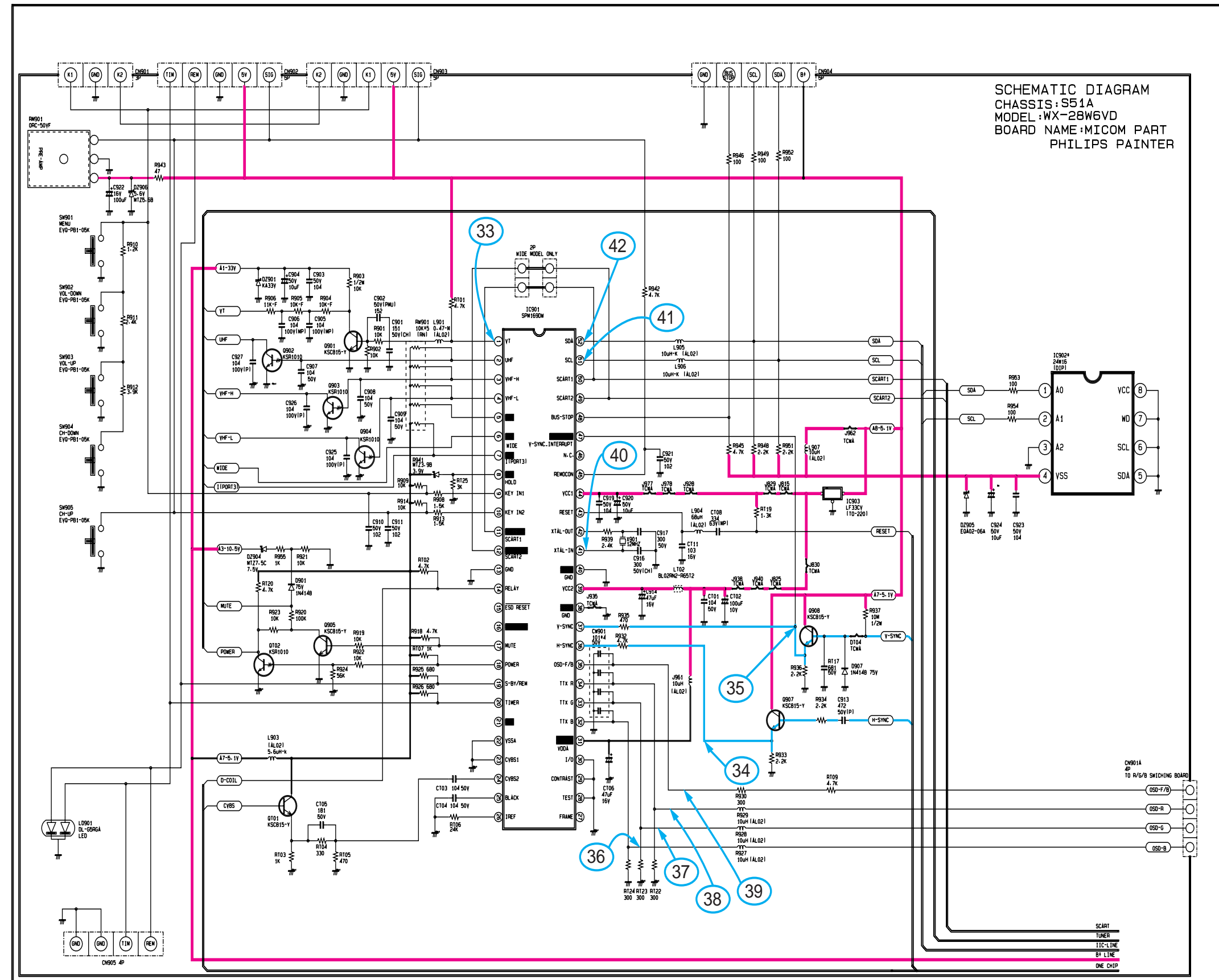

### 11-6 PWB MAIN (A/V-SWITCHING)

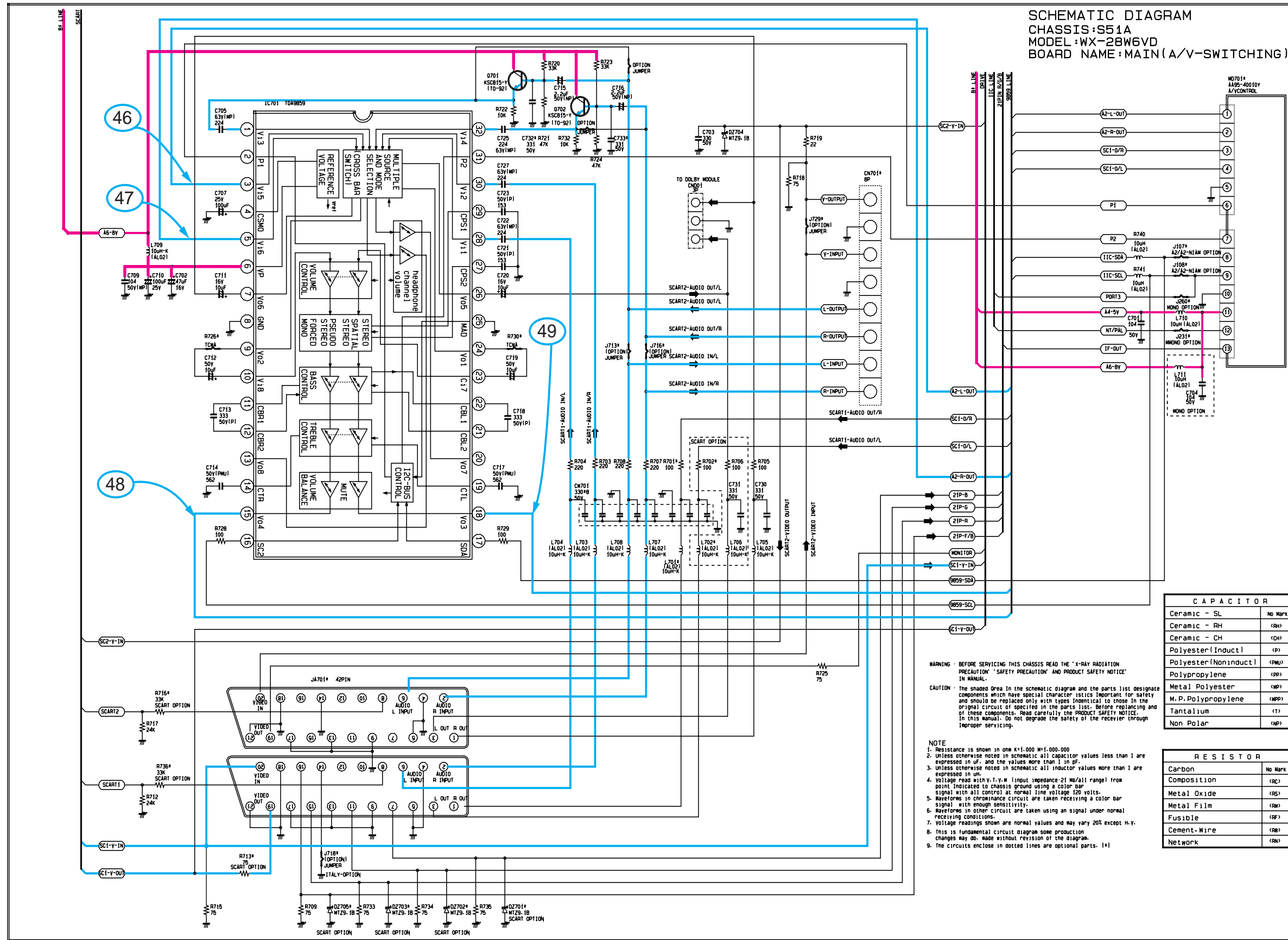

**SCHEMATIC DIAGRAM**  
 CHASSIS: S51A  
 MODEL: WX-28W6VD  
 BOARD NAME: MAIN (A/V-SWITCHING)

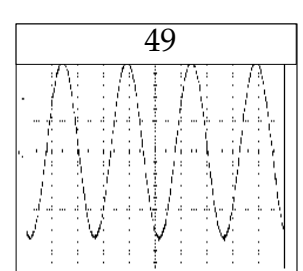
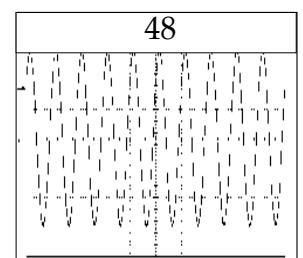
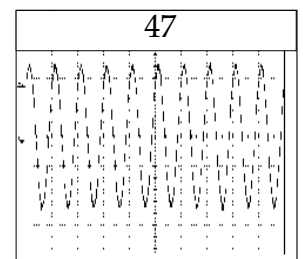
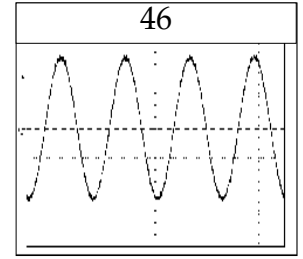

**WARNING:** BEFORE SERVICING THIS CHASSIS READ THE "X-RAY RADIATION PRECAUTION" "SAFETY PRECAUTION" AND PRODUCT SAFETY NOTICE IN MANUAL.

**CAUTION:** The shaded Area in the schematic diagram and the parts list designate components which have special characteristics important for safety and should be replaced only with types identical to those in the original circuit of specified in the parts list. Before replacing any of these components, read carefully the PRODUCT SAFETY NOTICE in this manual. Do not upgrade the safety of the receiver through improper servicing.

**NOTE**

1. Resistance is shown in ohm  $\times 1,000$  M=1,000,000
2. Unless otherwise noted in schematic all capacitor values less than 1 are expressed in  $\mu$ F, and the values more than 1 in pF.
3. Unless otherwise noted in schematic all inductor values more than 1 are expressed in  $\mu$ H.
4. Voltage read with V.T.V.M. (input impedance  $\geq 10$  M $\Omega$ ) range from point indicated to chassis ground using a color bar signal with all control at normal line voltage (230 volts).
5. Waveforms in chrominance circuit are taken receiving a color bar signal with enough sensitivity.
6. Waveforms in other circuit are taken using a signal under normal receiving conditions.
7. Voltage readings shown are normal values and may vary 20% except H.V.
8. This is fundamental circuit diagram some production changes may be made without revision of the diagram.
9. The circuits enclose in dotted lines are optional parts. (O)

CAPACITOR	
Ceramic - SL	(No Mark)
Ceramic - RH	(RH)
Ceramic - CH	(CH)
Polyester (Induct)	(P)
Polyester (Noninduct)	(PNP)
Polypropylene	(PP)
Metal Polyester	(MP)
M. P. Polypropylene	(MPP)
Tantalum	(T)
Non Polar	(NP)

RESISTOR	
Carbon	(No Mark)
Composition	(SC)
Metal Oxide	(SO)
Metal Film	(SF)
Fusible	(SFP)
Cement-Wire	(SW)
Network	(SN)

— : Power Line  
 — : Signal Line

11-7 PWB-SOUND (Nicom / Dolby)

6

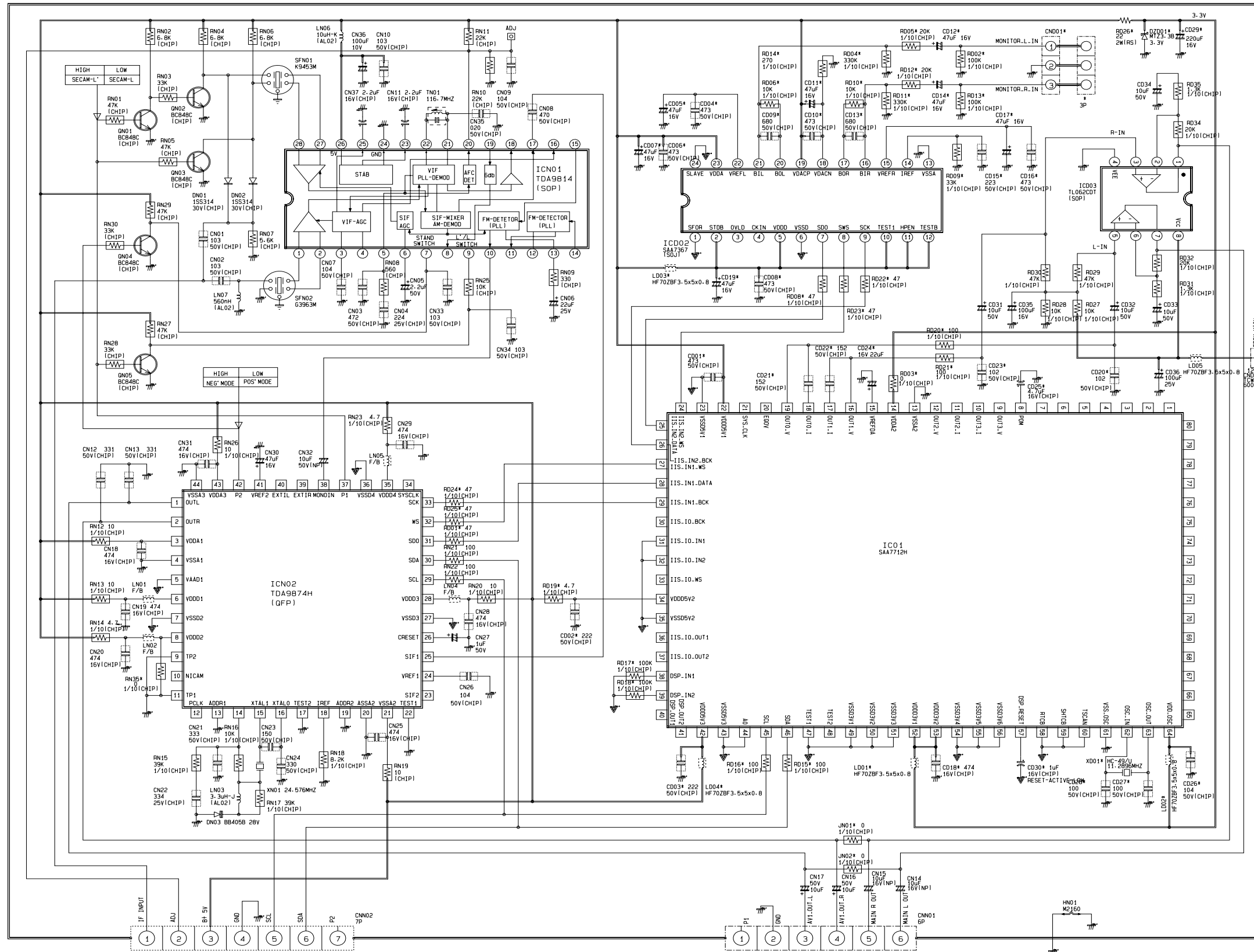

CAPACITOR

Ceramic - SL	No Mark
Ceramic - RH	<RH>
Ceramic - CH	<CH>
Polyester (Induct)	<P>
Polyester (Noninduct)	<PMU>
Polypropylene	<PP>
Metal Polyester	<MP>
M. P. Polypropylene	<MPP>
Tantalum	<T>
Non Polar	<NP>

RESISTOR

Carbon	No Mark
Composition	<RC>
Metal Oxide	<RS>
Metal Film	<RM>
Fusible	<RF>
Cement-Wire	<RW>
Network	<RN>

EXPRESSION  
 1 Resistance is shown om K=1.000 M=1.000.000  
 2 Unless otherwise noted in schematic all capacitor values less than 1 are expressed in uF, the values more than 1 in pF.  
 3 Unless otherwise noted in schematic all inductor values are expressed in mH and the values less than 1 in nH.

NOTE  
 The circuits are subject to change without notice to improve the picture quality.

SCHEMATIC DIAGRAM  
 CHASSIS : S51A  
 MODEL : SECAN-L.L' NICAM  
 BOARD NAME : NICAM/DOLBY

FILE NAME : SECAN-L.L A2 NICAM VIRTUAL-SURROUND

JOB-NO	TEAM	NODE	DESIGN	OPE	EDIT
	PAL	NC30	C.K. CHO		98.11.19

### 11-8 PWB MAIN (Sound Module Mono)

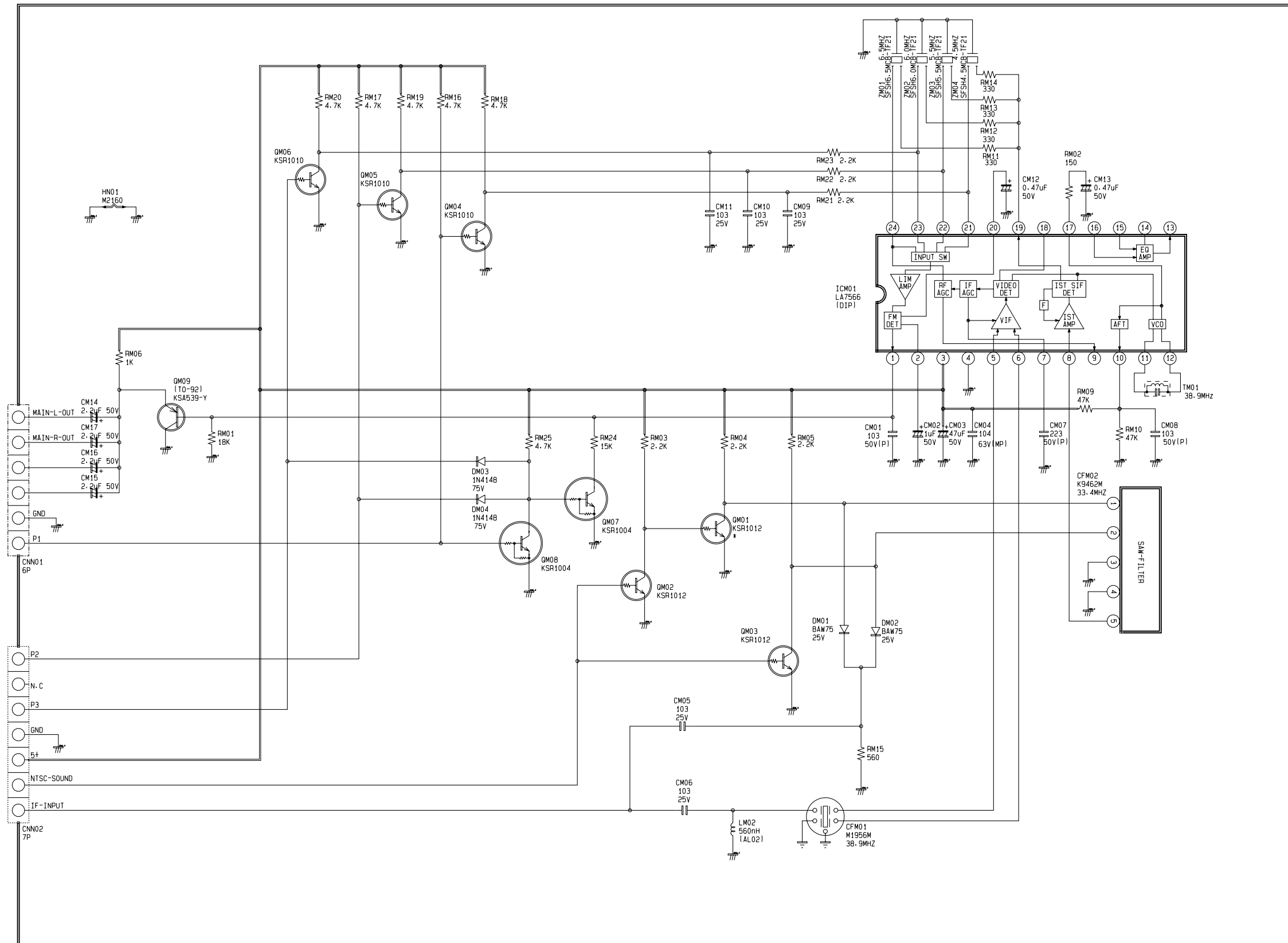



# 11-9 PWB MAIN (CRT-V/M)

WITHOUT VM (PHILIPS NORMAL CRT)

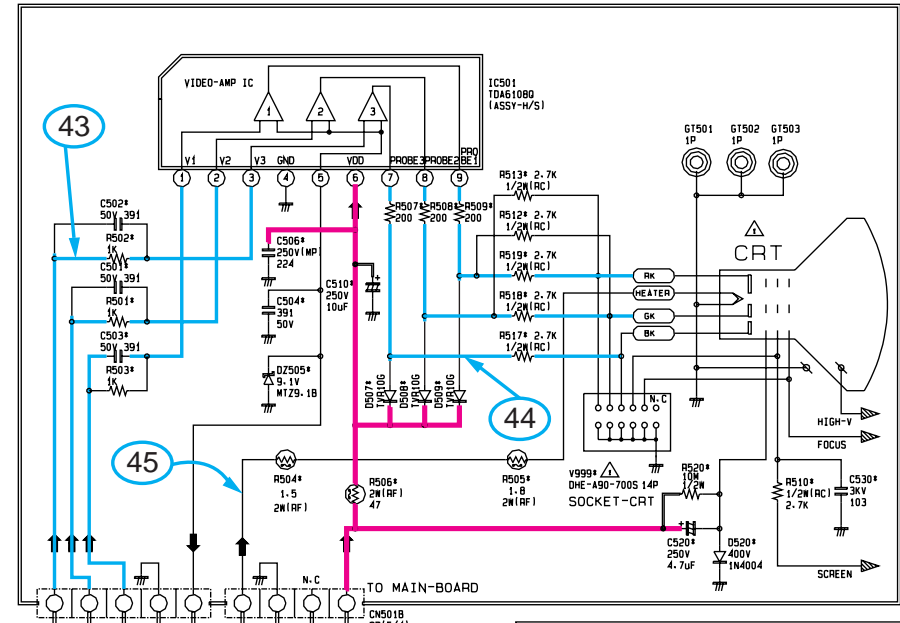

WITH VM (PHILIPS INVAR CRT)

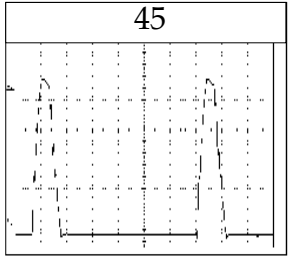
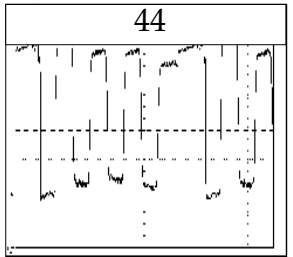
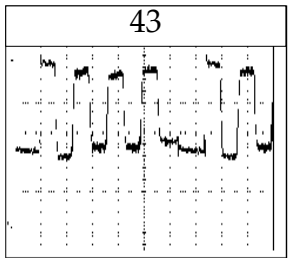
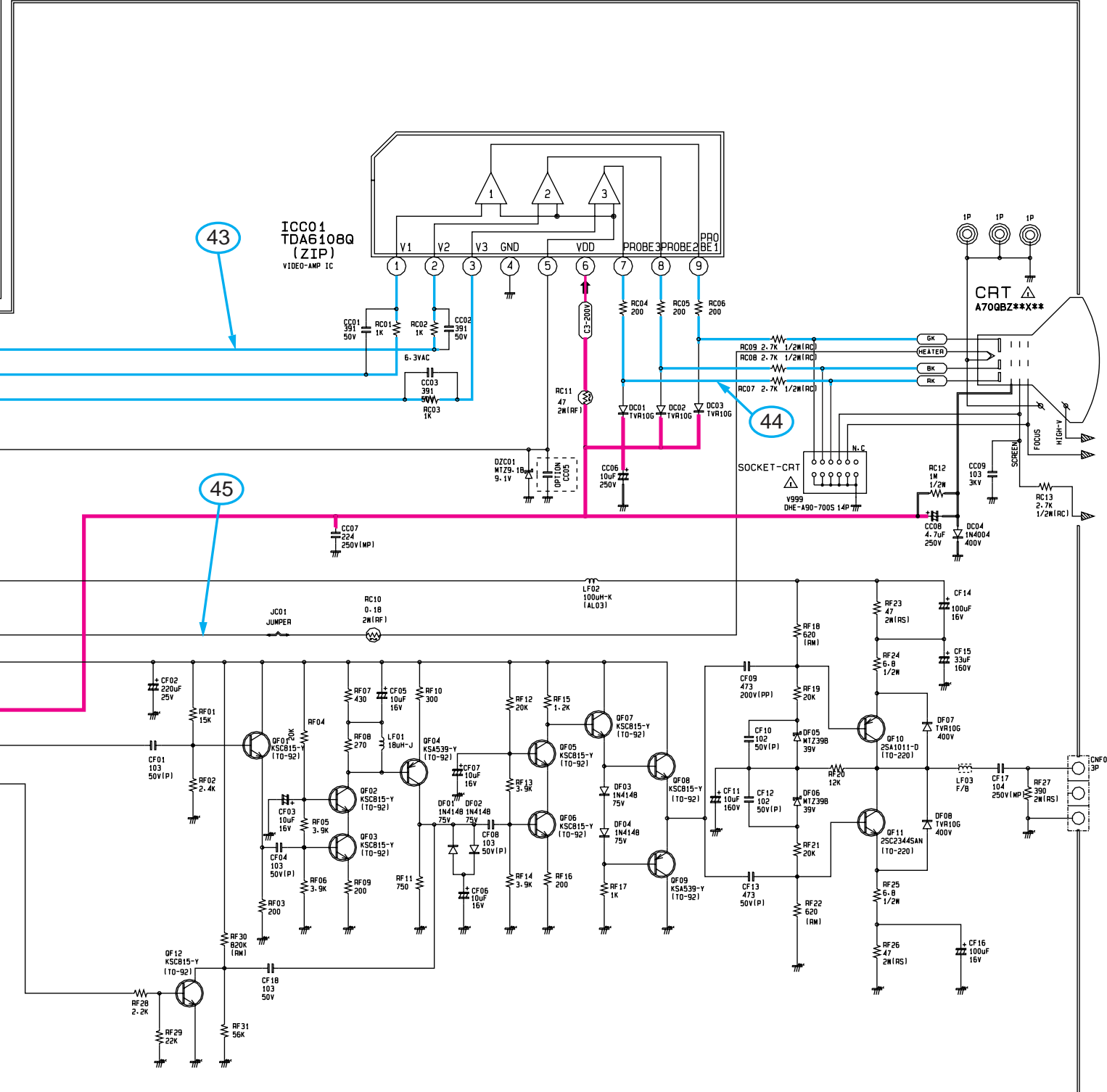

OPTION

NORMAL VS INVAR OPT OPTION

LOC. NO.	CODE NO.	SPEC.	PHILIPS INVAR OPT	PHILIPS NORMAL OPT	Remarks
C406	2306-000204	C-FILM.PHY-400V-434	2306-000195	C-FILM.PHY-400V-364	
C414	2306-000330	C-FILM.PHY-1.6KV-772	2306-000330	C-FILM.PHY-1.6KV-772	
C415	2306-000237	C-FILM.PHY-1.6KV-632	2306-000178	C-FILM.PHY-1.6KV-392	
C416	2306-000237	C-FILM.PHY-400V-223	2303-001026	C-FILM.PHY-400V-333	
R301	2001-001954	R-CARBON-1.2K-1/2W	2001-001049	R-CARBON-1.2K-1/2W	
R302	2001-001954	R-CARBON-1.5K-1/2W	2001-001049	R-CARBON-1.2K-1/2W	
R415	2008-001913	R-FUSIBLE-1.2A-250V	2008-001931	R-FUSIBLE-1.5A-18	
R417	2001-001952	R-CARBON-1/2W-47K	2004-001987	R-CARBON-1/2W-68K-F	
T444	A426-30025V	TRAG-FLYBACK-FUN94024	A426-30025V	TRAG-FLYBACK-FUN94023	
VS		ADD		NONE	
R205	2003-000998	R-METAL-151-2K-300	2003-002089	R-METAL-151-2K-470	
R206	2003-000998	R-METAL-151-2K-300	2003-002089	R-METAL-151-2K-470	
R208	2003-000998	R-METAL-151-2K-300	2003-002089	R-METAL-151-2K-470	

— : Power Line  
— : Signal Line

# 11-10 PWB MAIN (SOUND MODULE A2-STEREO)

6

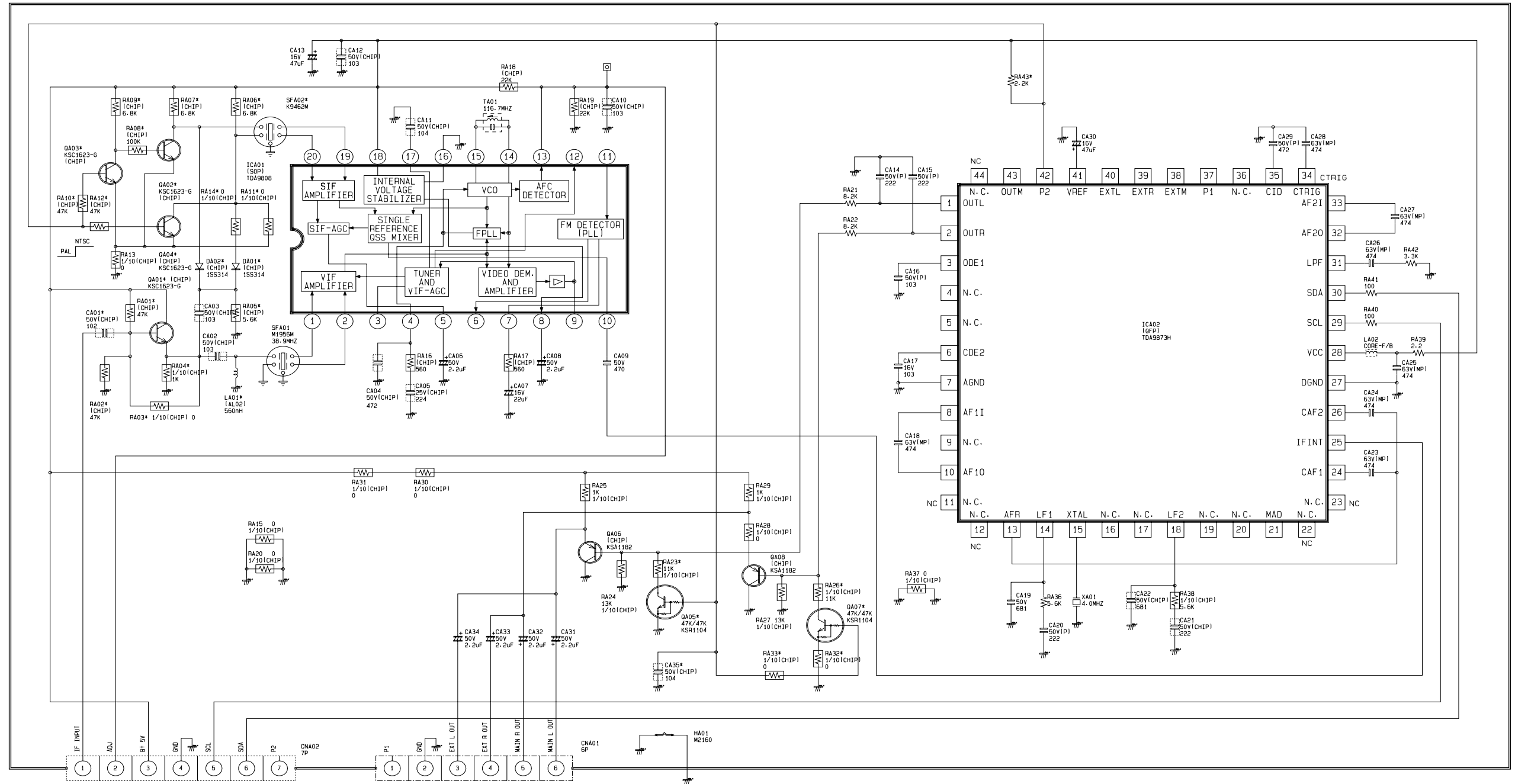

CAPACITOR	
Ceramic - SL	No Mark
Ceramic - RH	<RH>
Ceramic - CH	<CH>
Polyester (Induct)	<P>
Polyester (Noninduct)	<PMU>
Polypropylene	<PP>
Metal Polyester	<MP>
M.P. Polypropylene	<MPP>
Tantalum	<T>
Non Polar	<NP>

RESISTOR	
Carbon	No Mark
Composition	<RC>
Metal Oxide	<RS>
Metal Film	<RM>
Fusible	<RF>
Cement Wire	<RW>
Network	<RN>

EXPRESSION  
 1 Resistance is shown ohm K=1,000 M=1,000,000  
 2 Unless otherwise noted in schematic all capacitor values less than 1 are expressed in ufd. the values more than 1 in pF.  
 3 Unless otherwise noted in schematic all inductor values are expressed in uH and the values less than 1 in mH.

NOTE  
 The circuits are subject to change without notice to improve the picture quality.

SCHEMATIC DIAGRAM  
 CHASSIS: S51A  
 MODEL: CS29D9  
 BOARD NAME: SOUND MODULE  
 A2 STEREO

FILE NAME : A2

JOB-NO	TEAM	NODE	DESIGN	OPE	EDIT
	T.V.I.	NC20	Y-K KIM		1999-01-05



# 11-12 PWB MAIN (A/V FRONT / VIDEO SWITCH)

FRONT-A/V

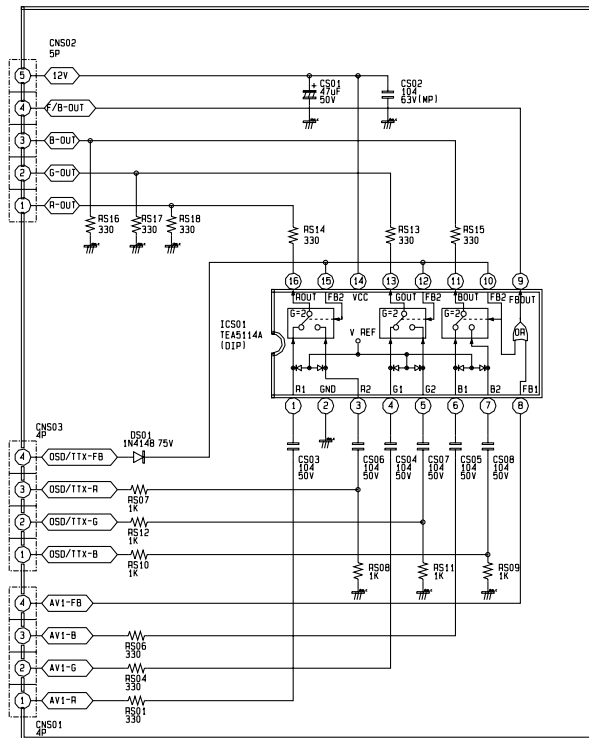
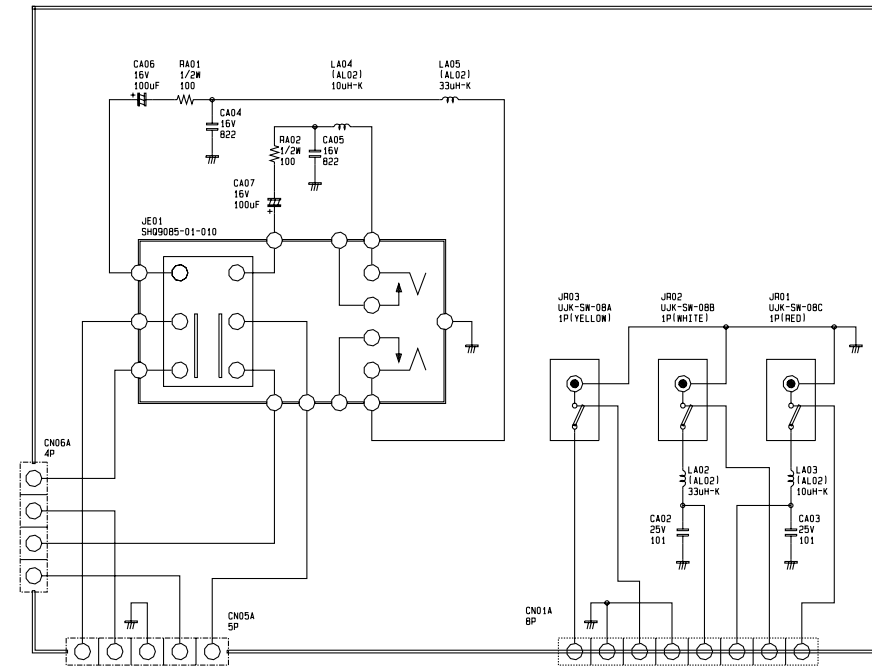

RGB - SW MODULE

CAPACITOR	
Ceramic - SL	No Mark
Ceramic - RH	<RH>
Ceramic - CH	<CH>
Polyester(Induct)	<P>
Polyester(Noninduct)	<PN>
Polypropylene	<PP>
Metal Polyester	<MP>
M.P.Polypropylene	<MPP>
Tantalium	<T>
Non Polar	<NP>

RESISTOR	
Carbon	No Mark
Composition	<RC>
Metal Oxide	<RS>
Metal Film	<RM>
Fusible	<RF>
Cement-Wire	<RW>
Network	<RN>

- NOTE
1. Resistance is shown in ohm K=1,000 M=1,000,000
  2. Unless otherwise noted in schematic all capacitor values less than 1 are expressed in  $\mu$ F, and the values more than 1 in pF.
  3. Unless otherwise noted in schematic all inductor values more than 1 are expressed in  $\mu$ H.
  4. Voltage read with V.I.V.M (input impedance 21 M $\Omega$ /all range) from point indicated to chassis ground using a color bar signal with all control at normal line voltage 120 volts.
  5. Waveforms in chromance circuit are taken receiving a color bar signal with enough sensitivity.
  6. Waveforms in other circuit are taken using a signal under normal receiving conditions.
  7. Voltage readings shown are normal values and may vary 20% except H.V.
  8. This is fundamental circuit diagram some production changes may be made without revision of the diagram.
  9. The circuits enclose in dotted lines are optional parts. [x]

WARNING : BEFORE SERVICING THIS CHASSIS READ THE "X-RAY RADIATION PRECAUTION" "SAFETY PRECAUTION" AND PRODUCT SAFETY NOTICE" IN MANUAL.

CAUTION : The shaded Area in the schematic diagram and the parts list designate components which have special characteristics important for safety and should be replaced only with types identical to those in the original circuit of specified in the parts list. Before replacing any of these components, Read carefully the PRODUCT SAFETY NOTICE. In this manual. Do not degrade the safety of the receiver through improper servicing.